

P		F		LTR		REVISIONS		DATE		APPROVED	
<input checked="" type="checkbox"/>	<input checked="" type="checkbox"/>	<input checked="" type="checkbox"/>	<input checked="" type="checkbox"/>	<input checked="" type="checkbox"/>	<input checked="" type="checkbox"/>	G	REV + REDWN	C82-516	5-25-83	<i>[Signature]</i>	

THIS DRAWING IS UNPUBLISHED. RELEASED FOR PUBLICATION MAY 25, 1983.
 BY AMP INCORPORATED, HARRISBURG, PA. ALL INTERNATIONAL RIGHTS RESERVED. AMP PRODUCTS MAY BE COVERED BY U.S. AND FOREIGN PATENTS AND/OR PATENTS PENDING.

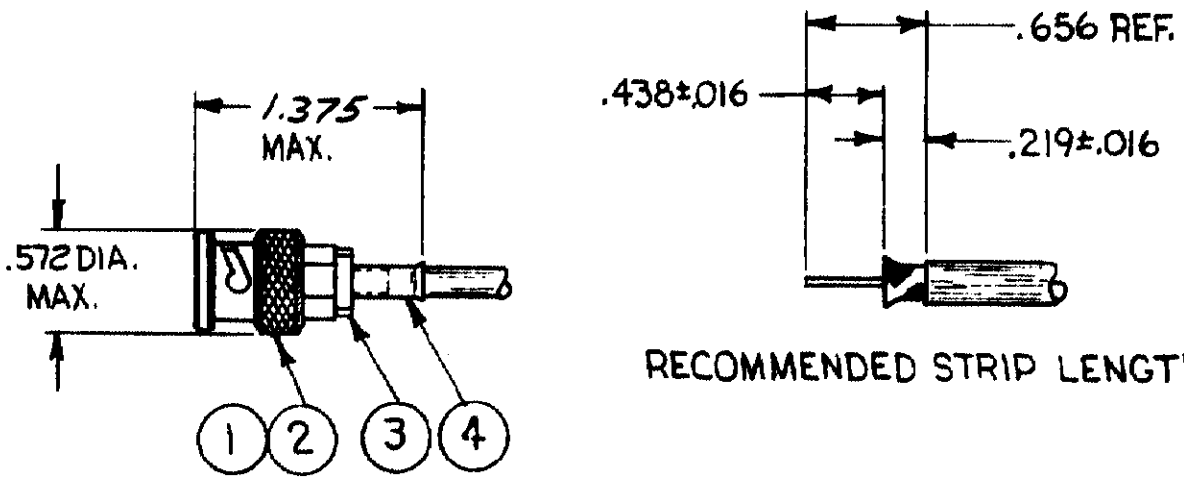

RECOMMENDED STRIP LENGTH

1. FOR USE WITH: RG-178/U + 196/U CABLE
2. USE CRIMPING TOOL: 69245-4.
3. SEE I.S. 1799-1
4. WEIGHT: .451 OZ.

ITEM	QTY.	DESCRIPTION	PART NO
4	1	FERRULE	328667
3	1	CRIMP END ASSV	1-50780-4
2	1	GASKET	2-329106-1
1	1	PLUG ASSY	329804

UNLESS OTHERWISE SPECIFIED DIMENSIONS ARE IN INCHES. TOLERANCES ON: DECIMALS ± # ANGLES ± #

MATERIAL: H

FINISH: H

CONTRACT NO

DR *[Signature]* 5-25-83

CHK *[Signature]* 9/12/83

APPD *[Signature]* 11/21/83

APPD *[Signature]* 11/21/83

DSGN APPD

OTHER APPD

AMP | AMP INCORPORATED
Harrisburg, Pa. 17105

NAME: **CONNECTOR, COAXIAL, R.F., PLUG, SERIES BNC**

SIZE: **A** FSCM NO: **00779** DRAWING NO: **330876**

SCALE: **NTS** SHEET: _____